

Lightweight Steel Fabrication Swing Lever

CATEGORY: Recommended

Summary: Acknowledging the service that the Carbon Fibre Swing Levers have now seen in production and that some failures are now being experienced, CarnaudMetalbox Engineering has introduced an ideal economical replacement.

The Carbon Fibre Swing Levers on our B4 machines are now between 12 and 17 years old.

The new lever design used in our 5000 machines is a ready-made replacement. We strongly recommend customers seriously consider and make provision for replacement. This will prevent any untimely and costly down time and ensure peace of mind

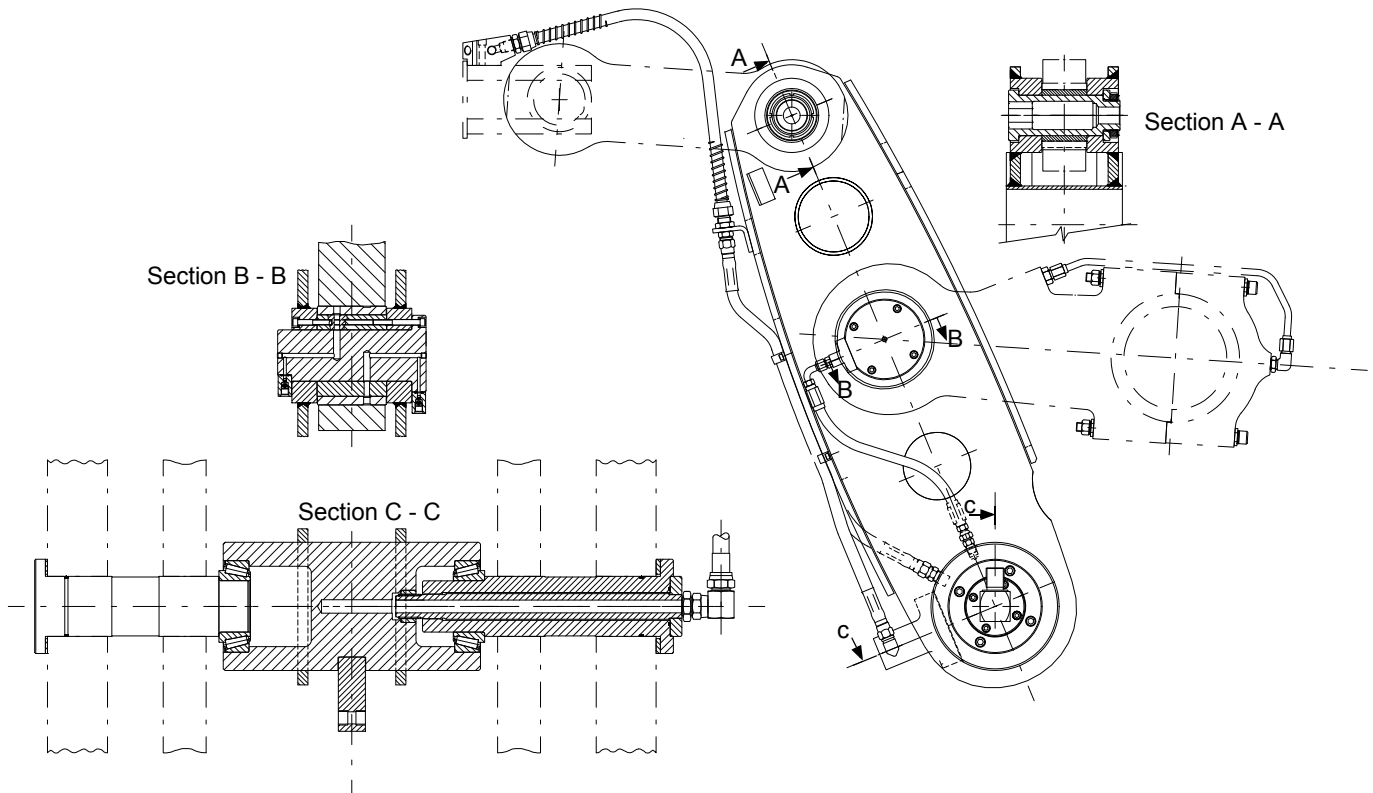

For further information regarding this Technical Bulletin please contact either of the contacts below quoting Technical Bulletin Number **TB-B3/B4-021** and your machine Serial Number

Note: a complete Library of Technical Bulletins is accessible on the Company Web Site.

Adrian Long,
CarnaudMetalbox Engineering Limited,
Dockfield Road, Shipley,
West Yorkshire, BD17 7AY, UK
Tel: +44 1274 846208, Fax: +44 1274 846201
email: adrian.long@eur.crowncork.com

Paul J Orsino III,
CarnaudMetalbox Engineering Limited,
79 Rockland Road, Norwalk,
Connecticut 06854, USA
Tel: +1 203 853 7325, Fax: +1 203 866 7627
email: porsino@crowncork.com