

IBR Pusher Ram Drive Key Modification

CATEGORY: Recommended at next scheduled overhaul maintenance.

Summary: CarnaudMetalBox introduce a design update to counter the effects of repetitive motion 'fretting' on the Pusher Ram Drive Key of the Internal Base Reformer (IBR) after prolonged periods of use.

Instances of 'fretting' have been reported between the RAM (Item 8), Compliance Plunger (Item 13) and the Key (Item 37).

After investigation by CarnaudMetalBox engineers it has been decided that replacing the existing steel key (**Part Number 26422202**) with a 'Lead Bronze' Drive Key (**Part Number 4051129B**) would reduce the wear on items 8 and 13. **See highlighted section in Fig.1 below.**

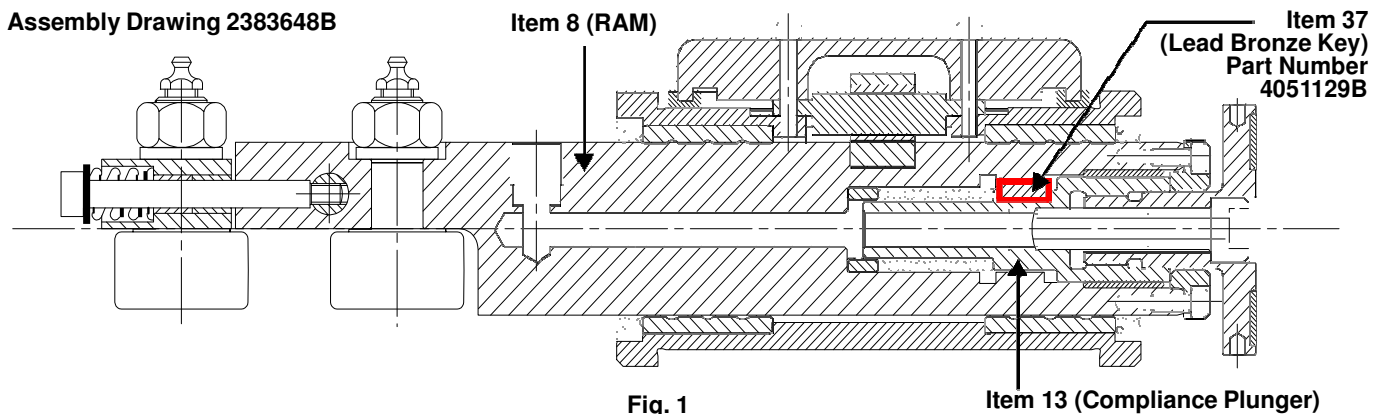

Recommended Action for Customers

At the next scheduled overhaul maintenance disassemble each IBR Pusher Ram assembly and inspect for 'fretting' between the three items detailed above.

If damage is found replace all three items with the latest issue parts available from CarnaudMetalbox Engineering.

If minimal 'fretting' damage is evident (less than 0.1mm oversize key slots) on items 8 or 13 then item 37 should be replaced with **Part Number 4051129B** to reduce wear on the RAM and Compliance Plunger.

Replacement with this 'Softer' key will increase wear on this 'sacrificial' part which will now require replacement on a 12 monthly basis. **See revised IBR maintenance schedule in machine manual.**

For further information regarding this Technical Bulletin please contact either of the contacts below quoting Technical Bulletin Number **TB3400-011** and your machine Serial Number

Note: a complete Library of Technical Bulletins is accessible on the Company Web Site.

CarnaudMetalbox Engineering Limited,
Dockfield Road, Shipley,
West Yorkshire, BD17 7AY, UK
Tel: +44 1274 846200, Fax: +44 1274 846201
[email:sales@CMBEcanmaking.com.com](mailto:sales@CMBEcanmaking.com.com)

Engineering Limited,
79 Rockland Road, Norwalk,
Connecticut 06854, USA
Tel: +1 203 853 7325, Fax: +1 203 866 7627
[email: sales@CMBEcanmaking.com](mailto:sales@CMBEcanmaking.com)