

Addition of Waved Preload Washers to Radial Flanging Heads

CATEGORY: Advised At Next Maintenance

Carnaud Metalbox Engineering have enhanced the bearing arrangement for Flanging Heads on their 3400 Die Necker. To further extend the life of the bearings by minimising bearing vibrations, Waved Preload Washers have been included in the design.

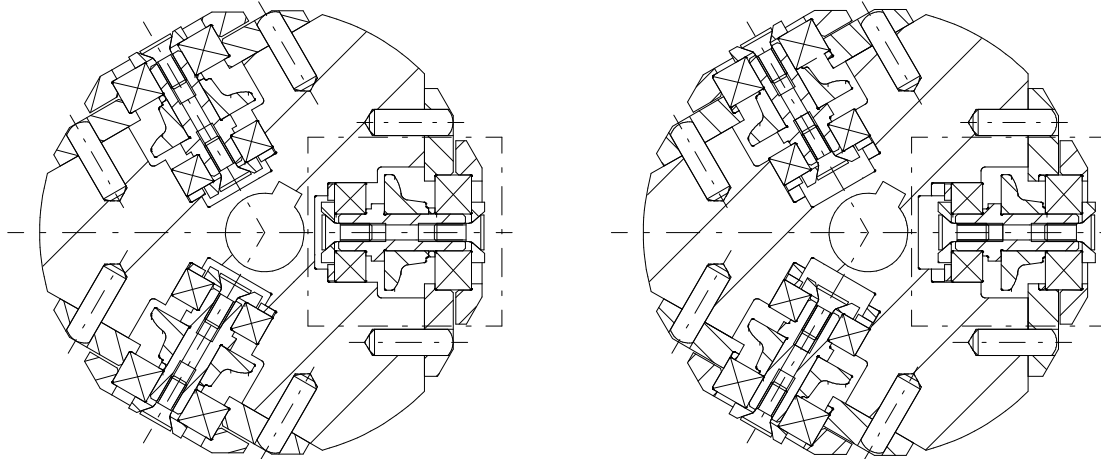

202 Neck Size

206 Neck Size

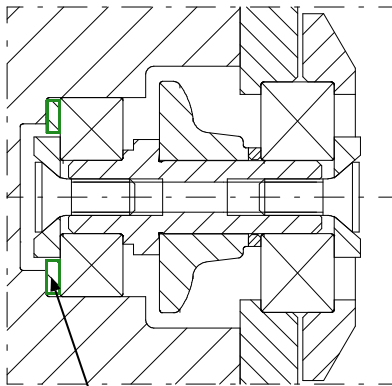

Waved Washer
Part Number 27576213

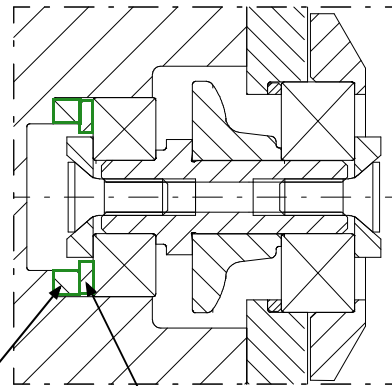

206 Spacer
Part Number 2397500

Waved Washer
Part Number 27576213

The preload Wavy Washer (3 off per Head Assembly) is simply positioned as shown adjacent to the bearing.

In the case of a 206 neck size a Spacer (3 off per Head Assembly) is also required, positioned as shown.

For further information regarding this Technical Bulletin please contact either of the contacts below quoting Technical Bulletin Number **TB3400-001**

Note: a complete Library of Technical Bulletins is accessible on the Company Web Site.

CarnaudMetalbox Engineering Limited,
Dockfield Road, Shipley,
West Yorkshire, BD17 7AY, UK
Tel: +44 1274 846200, Fax: +44 1274 846201
[email: sales@CMBEcanmaking.com](mailto:sales@CMBEcanmaking.com)

CarnaudMetalbox Engineering Limited,
79 Rockland Road, Norwalk,
Connecticut 06854, USA
Tel: +1 203 853 7325, Fax: +1 203 866 7627
[email: sales@CMBEcanmaking.com](mailto:sales@CMBEcanmaking.com)