

CATEGORY: Recommended for immediate implementation.

Summary: Bodymaker main drive failure After separate isolated incidents of electrical fires occurring with the resistor enclosures on the Bodymaker control panels, it has been decided to introduce a new DC circuit breaker (Eaton Moeller CB PKZ-SOL12) to protect the circuit and to also physically disconnect all power from the Bodymaker main drive to the resistors under fault conditions. Also, an auxiliary contact has been added which is connected to the PLC input, this removes the 'drive enable' and 'run' signals (see circuit drawing below).

The issue occurs when the fault current is generated on Braking Resistor terminals BR1 and BR2 due to a faulty PF700. The braking resistors are not physically disconnected from the source of the fault by the overload protection device, which in turn, leads to the potentially high DC currents.

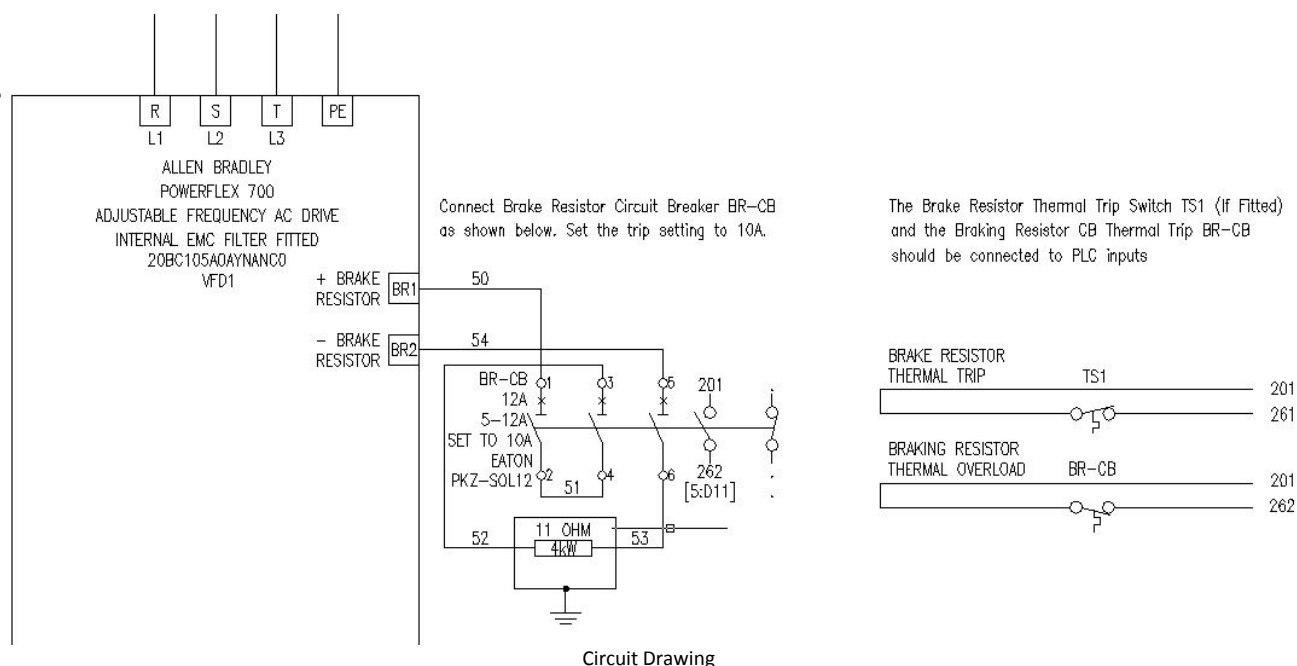

The modified circuit (Eaton Moeller CB PKZ-SOL12) has been rigorously tested under fault conditions. Results confirm that the correct electrical protection of the braking resistors has been achieved.

CarnaudMetalBox Ltd strongly recommend that this Technical Bulletin be implemented across all 5000 Bodymakers affected by this electrical issue. Please contact your sales [representative](#) for further information.