



ENGINEERING

# Technical Bulletin

**TB5000-052**

Sheet: 1 of 1

5000 Bodymaker

Issue: 06. 07. 09

## Clamping Cover Dampening Assembly

**CATEGORY:** Recommended

Summary: In conjunction with customers operator comments regarding the weight of the Toolpack Lid on the 5000 MK2 Bodymakers, CarnaudMetalbox Engineering have introduced a new Clamp Cover Dampening Assembly.

This Assembly uses a Gas Strut to support the weight of the Toolpack Lid, giving the machine operator an easier lift.

Simple and easy installation means this improvement will be a must for all Canmakers..

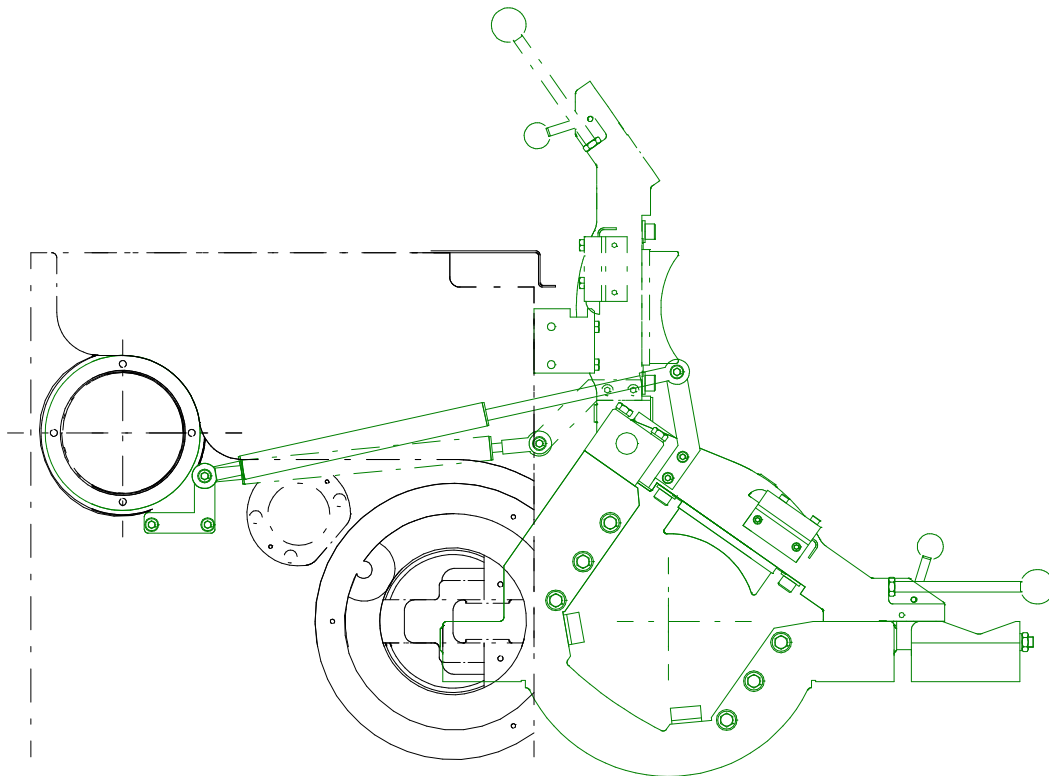

For further information regarding this Technical Bulletin please contact either of the contacts below quoting Technical Bulletin Number **TB5000-052** and your machine Serial Number.

Note: a complete Library of Technical Bulletins is accessible on the Company Web Site.

CarnaudMetalbox Engineering Plc,  
Dockfield Road, Shipley,  
West Yorkshire, BD17 7AY, UK  
Tel: +44 1274 846200, Fax: +44 1274 846201  
**email: [sales@CMBEcanmaking.com](mailto:sales@CMBEcanmaking.com)**

CarnaudMetalbox Engineering Plc,  
79 Rockland Road, Norwalk,  
Connecticut 06854, USA  
Tel: +1 203 853 7325, Fax: + 1 203 866 7627  
**email: [sales@CMBEcanmaking.com](mailto:sales@CMBEcanmaking.com)**